

HEAD JAMB

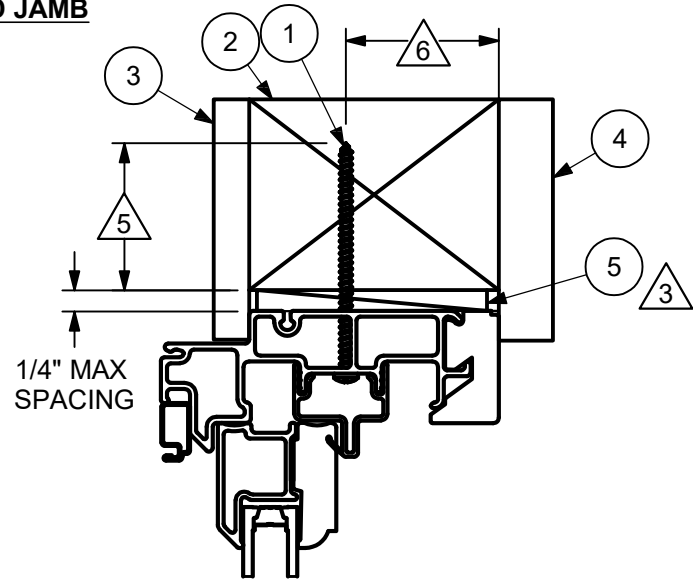

JAMB

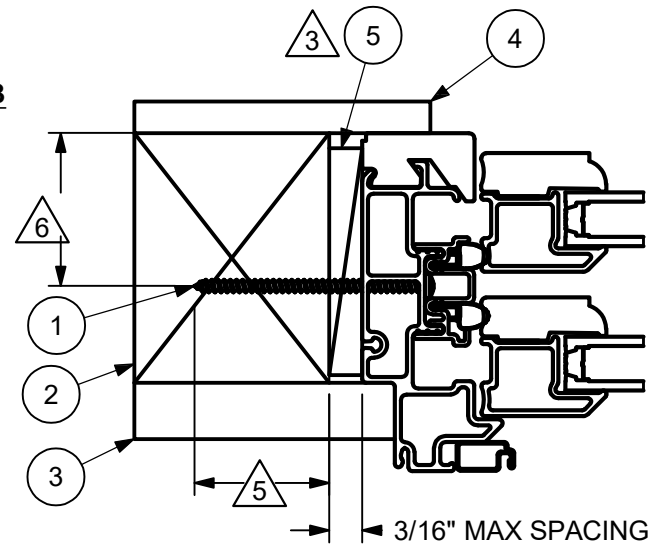

SILL

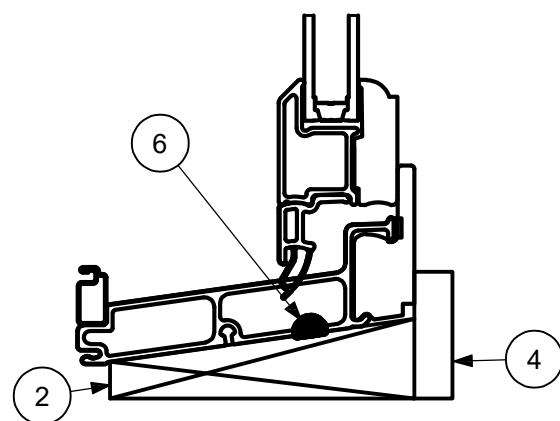

CATEGORY:
DOUBLE HUNG

UNIT TYPE:
ELDHIN,
ELDHIN P

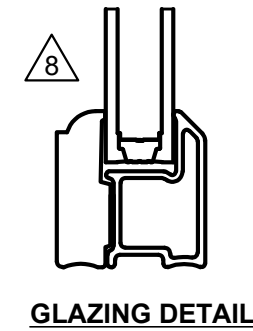
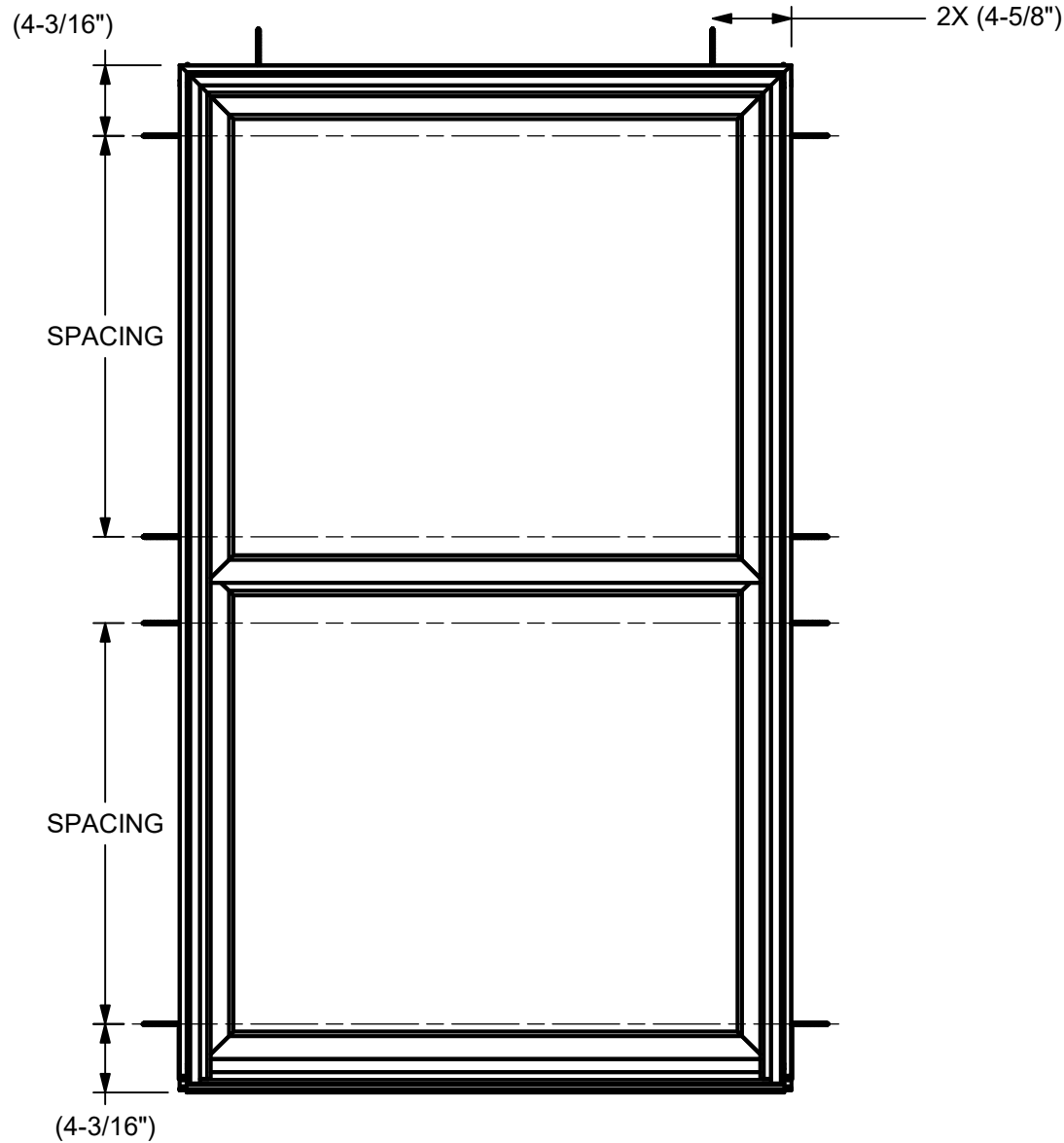

UNIT	MAX FRAME SIZE	DP RATING
ELDHIN	42-1/16 X 84-1/2	+40/-40
ELDHIN	54-1/16 X 84-1/2	+35/-35
ELDHIN P	62 X 84-1/2	+40/-40

THROUGH JAMB/ HEAD JAMB SCREW QUANTITIES			
FRAME TYPE	HEADER	FRAME TYPE	JAMBS
ELDHIN > 42" WIDE	2	ALL ≥ 36-1/2" TALL	3
ELDHIN < 42"	0	ALL > 74-3/8"	4

THROUGH JAMB INSTALLATION:

- SECURE THE JAMBS THROUGH ALL PRE-DRILLED HOLES WITH #8 X 3" PAN HEAD SCREWS
- MAXIMUM SPACING OF JAMBS NOT TO EXCEED 35-9/16"
- SECURE THE HEAD JAMB WITH #8 X 3" PAN HEAD SCREWS AS INDICATED ON CHART
- PLACE A U-SHAPED BEAD OF SEALANT ON THE SILL PANNING

NOTES:

- FOR GENERAL SPECIFICATIONS, REFER TO DOC 00003952
- THIS PRINT IS FOR STRUCTURAL PERFORMANCE ONLY. FOR FLASHING AND SEALING INSTRUCTIONS REFER TO THE INSTALLATION INSTRUCTIONS
- SHIMS:
 - PLACE SHIMS A MAX OF 6" FROM EACH CORNER AND 12" ON CENTER
 - PLACE A SHIM WITHIN 1" OF EACH THRU JAMB SCREW
- IF CHEMICALLY TREATED LUMBER IS USED FOR A BUCK MATERIAL, FASTENERS INTO THE BUCK MUST BE A MINIMUM OF 0.90 OZ/FT² ZINC HOT DIPPED GALVANIZED OR STAINLESS STEEL TYPE 304 OR 316
- MINIMUM SCREW EMBEDMENT DEPTH: 1-13/16"
- MINIMUM SCREW EDGE DISTANCE: 1"
- FOR THROUGH JAMB SCREW QUANTITY, REFER DOC 00114414, 00083628 OR 00083629
- GLASS COMPLIES WITH ASTM E1300

ITEM	DWG NO	DESCRIPTION
6	NA	SILICONE
5	NA	SHIMS
4	NA	INTERIOR STOPS OR TRIM
3	NA	EXISTING BLIND STOP
2	NA	TREATED FRAME MATERIAL
1	00003264	#8-18 X 3.000" TYPE AB, FULL THREAD

PARTS LIST

MARVIN RESEARCH & DEVELOPMENT

COLLECTION: ELEVATE

DWG TYPE: INSTALLATION
DESCRIPTION: INSTALLATION ELEVATION/METHOD, THROUGH JAMB

CHK: JDD	SIZE: B	CLASS: ASSY	DWG NO: 00115532
09/13/23			
APP: CRR	SCALE: 1/11	DATE: 10/17/2018	DWG BY: f_justins
09/13/23			SHEET: 1 OF 2

REV	DESCRIPTION / REQUESTOR	ECN NO	DATE	REV BY
2	ADDED GLAZING DETAIL AND SIZE CHART	27575	8/22/2023	JH
1.2	ADDED HEADER END PLUGS, UPDATED CHECKRAIL WEATHERSTRIP, UPDATED TEMPLATE	25450	7/13/2021	JHS

NOTICE - CONFIDENTIAL INFORMATION

The information in this document is privileged and strictly confidential. The information contained herein shall be used only by Marvin employees and by those agents or suppliers granted official written permission. If the reader of this document is not the intended recipient, or the employee or agent of the intended recipient, please delete this document from all data storage devices, and destroy all hard copies. Any unauthorized dissemination, distribution, copying or other use of the information contained in this document is strictly prohibited.